

General Description

The Rane SM 82 is a product offering incredible power and versatility. It is the equivalent of a *sixteen* channel mixer in one rack space. Measuring only 5.25 inches deep, it can do the job of mixers costing several times as much while only occupying a fraction of the rack space. It is ideally suited for keyboards, synthesizer expander modules and drum machines, as well as such things as effects mixing in guitar racks. It also functions as an excellent submixer for stereo line inputs and effects to a larger console. Because of shorter internal signal paths, it is much cleaner than many mixers ten times the cost and size.

Each of the 8 Stereo (two channel) input channels feature a stereo rotary input Level control, a stereo aux Send level control slider and a left to right Balance control slider. When a single mono input is used, the Balance control acts as a pan pot. The aux return section provides a rotary Return Level

control and a slide control for left to right Balance. The output stage includes a rotary Output Level control and a slide control for left to right Balance.

The human engineering applied to the SM 82 makes it extremely easy to operate. The segregation of function between rotary and slide controls (rotary for all input and output Levels and slide for Balance and Send) makes it simple to use, even in the dark.

The SM 82 is fully expandable using the ¼" TRS Main Expand Input and Output jacks. Expansion is as simple as connecting a stereo ¼" jumper cable from the first unit's Expand Output jack to the second unit's Expand Input jack. Now, two SM 82 units create a 16 channel stereo (32 input) line level Mixer in just two rack spaces. The Guinness publishing people will want to know about a 32 input mixer in two rack spaces for just a bit over \$1,000.00!

Features

- 8 Stereo Input Channels
- 1 Stereo Auxiliary Send
- 1 Stereo Auxiliary Return
- Stereo Balance Controls
- Balanced Stereo Output
- Expandable
- UL/CSA/CE and 100/120/230 VAC Remote Power Supplies

STEREO LINE MIXER

Parameter	Specification	Limit	Units	Conditions/Comments
Input Impedance: Ch's 1-8	100k	20%	ohms	
.....Receive	100k	20%	ohms	
.....Expand	20k	1%	ohms	
Input Level: Nominal	+4	1	dBu	
.....Minimum	-10	1	dBV	
.....Maximum	+26	1	dBu	
Input Design	Unbalanced			
Input Connectors: Ch's 1-8	¼" mono TS (tip-sleeve)			
.....Receive	¼" mono TS			
.....Expand	¼" stereo TRS (tip-ring-sleeve)			Tip=Left; Ring=Right
Input Gain Range	Off to +6	1	dB	
RFI Input Filters	Yes			
Max Output Level: Main	+26 (+20)	1	dBu	Balanced (Unbalanced)
.....Loop Send	+20	1	dBu	Unbalanced
.....Expand	+20	1	dBu	Unbalanced
Output Impedance: Main	100	1%	ohms	Each Output
.....Loop Send	100	1%	ohms	
.....Expand	100	1%	ohms	
Output Design: Main	Active Balanced/Unbalanced			Differential line drivers
.....Loop Send	Unbalanced			
.....Expand	Unbalanced			
Output Connectors	¼" TRS			
Output Gain Range	Off to +6	2	dB	Unbalanced
Frequency Response	20 Hz-20 kHz	.3	dB	
THD + Noise	.015	.005	%	+4 dBu, 20-20 kHz
IM Distortion (SMPTE)	.01	.005	%	60 Hz/7 kHz, 4:1, +4 dBu
Input Referred Noise	-112	1	dBu	
Signal-to-Noise Ratio	98 (re +4 dBu, 20 kHz BW)	2	dB	All inputs max, 50% out level, bal
Crosstalk	76 (1 kHz)	2	dB	Left-Right
	85 (1 kHz)	2	dB	Channel-Channel
Overload LED Thresholds	+16	1	dBu	All critical nodes monitored
Unit: Agency Listing				
.....120 VAC model	Class 2 Equipment UL & CSA			National Electrical Code Exempt Class 2 equipment
.....230 VAC model	CE-EMC CE-Safety			EMC directive 89/336/EEC Exempt per Art. 1, LVD 73/23/EEC
Power Supply: Agency Listing				
.....120 VAC model	UL CSA			Class 2 Equipment File no. E88261
.....230 VAC model	CE-EMC CE-Safety			File no. LR58948 EMC directive 89/336/EEC LV directive 73/23/EEC
.....100 VAC model	Built to JIS			Japan only
Power Supply Requirement	18-24 VAC w/center tap			RS 1 (included)
Maximum Current	650		mA	
Unit: Construction	All Steel			
.....Size	1.75"H x 19"W x 5.3"D			(4.4 cm x 48.3 cm x 13.5 cm)
.....Weight	5 lb			(2.3 kg)
Shipping: Size	4.25" x 20.3" x 13.75"			(11 cm x 52 cm x 35 cm)
.....Weight	10 lb			(4.5 kg)
<i>Note: 0 dBu=0.775 Vrms</i>				

Block Diagram

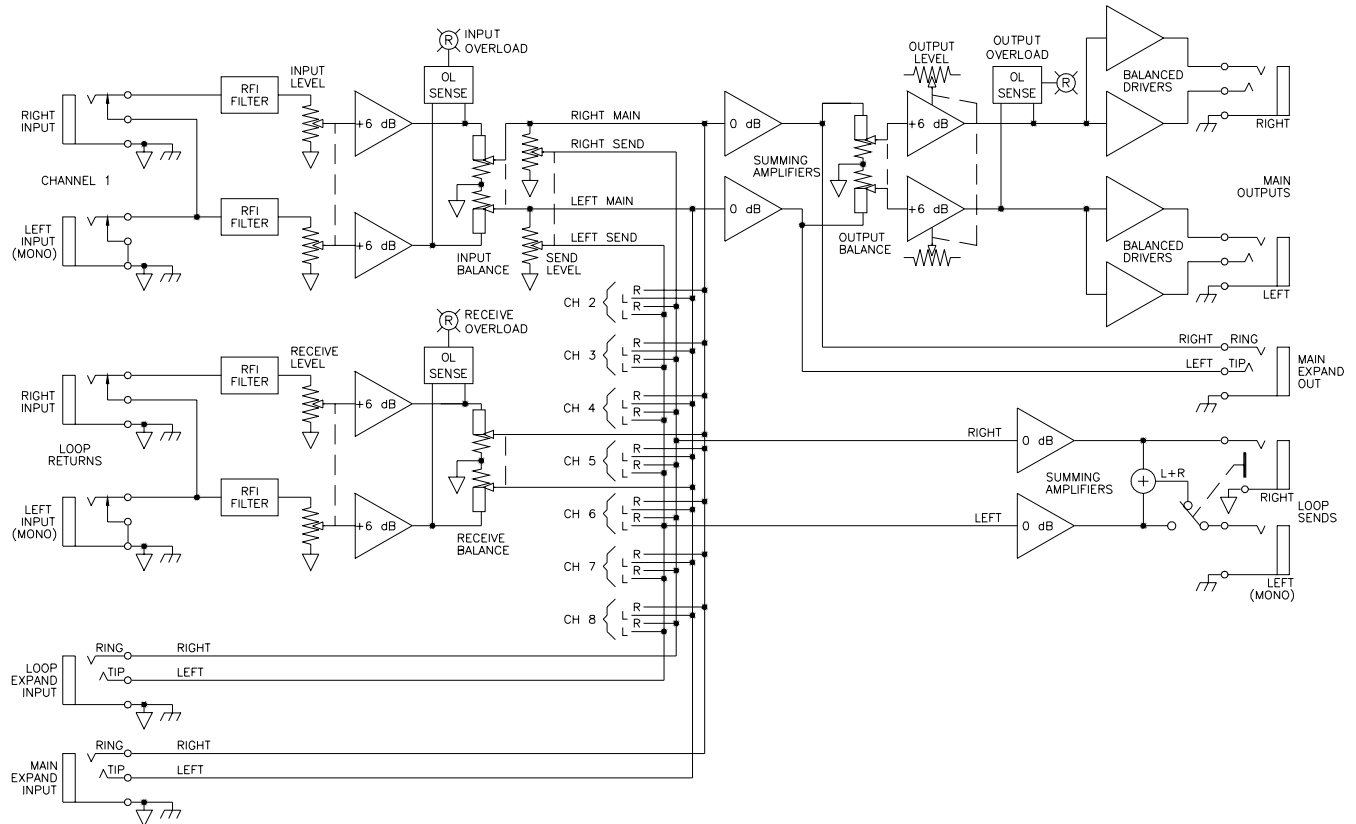

Application Information

The SM 82 allows you to mix eight Stereo line level Inputs down to a main Stereo Output. Additionally you can create a separate Stereo Loop Send mix for driving any stereo, or mono, external processor, and then return from this processor into the Stereo Loop Return Inputs. The stereo Return Level control is used to set the desired mix of wet and dry signals.

For applications not requiring the looping facilities, the Loop Return Inputs double as a fully functional 9th Stereo Input, creating a 9-Input Stereo Mixer. When used this way, the Loop Send Outputs become a separate Stereo Output pair, useful for monitor sends, taping outputs, or any other application.

When not used for expansion, the Main Expand Output pair double as a pre-fader stereo mix, again useful as tape outputs, or any other fixed-level application.

Mono sources and external processors are handled easily by the SM 82. Connecting only to any Left Input Jack automatically routes this signal to the Right channel so an equal Left/Right signal is summed into the mains. Similarly, connecting only to the Left Loop Send output gives you an equal mono L+R output send for mono input processors.

The question arises regarding mic levels. Since the SM 82 operates only at line levels, microphone applications require separate boosting before connection. Rane offers a mic stage model MS 1 ideally suited to this application.

Rear Panel

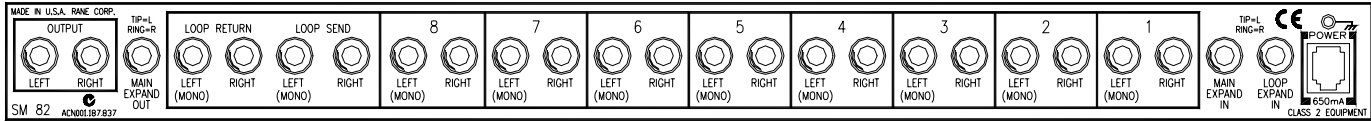

Home Studio Application Diagram

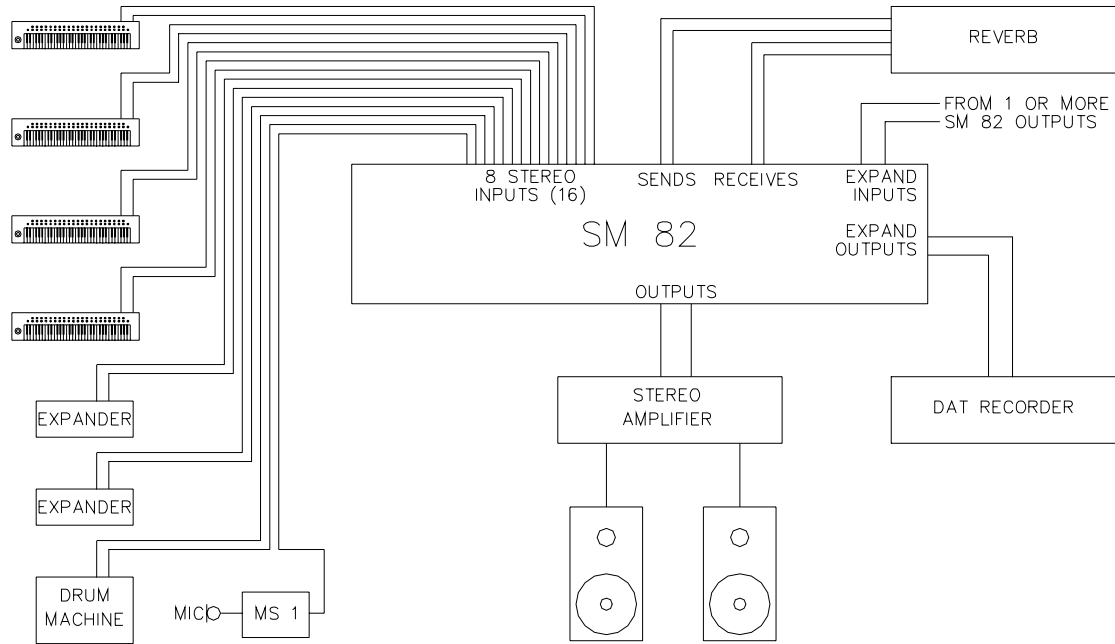

Architectural Specifications

The line level stereo mixer unit shall have eight (8) stereo (total of 16) inputs, one main stereo output pair, one stereo loop send pair, one stereo loop receive pair, loop and main stereo expand inputs, and one stereo main expand output. All inputs, as well as the loop send output, shall be configured such that plugging only into the left input (or output) will mono the system. Each stereo input shall have a rotary ganged level control with a range of off to +6 dB gain and a separate input overload LED. Separate +6 dB gain master rotary ganged stereo output level control shall be provided. In addition, stereo slider-type balance controls shall be provided for all inputs and outputs, along with stereo slider-type send level controls on all inputs.

Complete stereo expansion capabilities shall be provided

to allow any number of similar units to be coupled together.

The inputs shall be high impedance (100k Ohms) unbalanced designs terminated with ¼" TS (tip-sleeve) connectors. The outputs shall be active differentially balanced with balanced output impedance equal to 200 Ohms terminated with ¼" TRS (tip-ring-sleeve) connectors. RFI filters shall be provided.

The unit shall be exempt from agency safety requirements and powered from a UL listed / CSA certified remote power supply (120 VAC), or CE certified (230 VAC) design via a rear panel input modular plug. The unit shall be constructed entirely from cold-rolled steel, and mount into a standard EIA relay rack occupying 1 rack-space.

The unit shall be a Rane Corporation Model SM 82.

Available Accessories

- SC 1.7 Security Cover
- MS 1 Microphone Preamplifier